

Ampeg®

VENTURE V3, V7, and V12 Bass Amplifiers

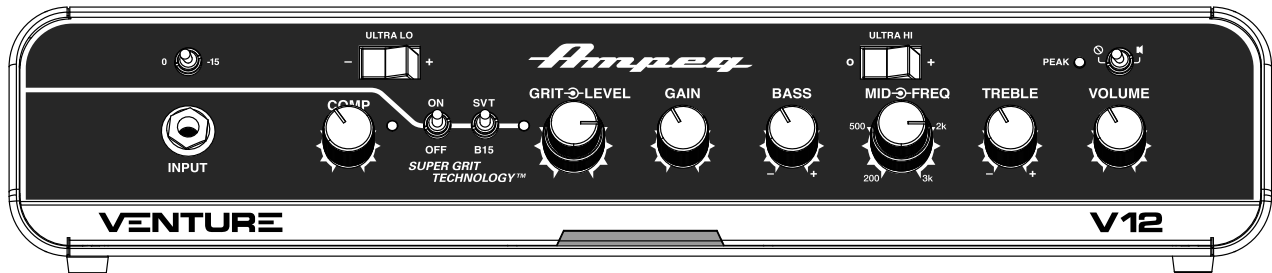

OWNER'S MANUAL

TABLE OF CONTENTS

What's in the Box	3
Introduction	3
Features	3
Getting Started	3
Hookup Example - Venture V3	4
Hookup Example - Venture V7 and V12	5
Front Panels	6
Front Panel Descriptions	7
Rear Panels	8
Rear Panel Descriptions	9
Venture V3 Technical Specifications	11
Venture V7 Technical Specifications	12
Venture V12 Technical Specifications	13
Warranty and Support	14

**Supplier's Declaration of Conformity
47 CFR § 2.1077 Compliance Information**

Unique Identifiers: Ampeg® Venture® V3, V7, and V12 Bass Amplifiers

Responsible Party - U.S. Contact Information:

Yamaha Guitar Group, Inc.
26580 Agoura Road
Calabasas, CA 91302-1921
(818) 575-3600 <https://ampeg.com/>

FCC Compliance Statement:

This device complies with Part 15 of the FCC Rules. Operation is subject to the following two conditions: (1) This device may not cause harmful interference, and (2) this device must accept any interference received, including interference that may cause undesired operation.

There are various types of fuses, and replacing them with different types may cause malfunction, electric shock, or fire. Be sure to confirm you are replacing the correct fuse with electrical rating and specifications.

Each number and symbol represent the following:

Example: T3AL250V

① T, ② ● A, ③ L, and ④ ■V are shown below.

- ① Symbol indicating relative fusing time / current characteristics T: Time lag type, F: Fast-acting type.
- ② ● A: Rated current.
- ③ Symbol indicating the blocking capacity L: Low cutoff capacity, E: Medium cutoff capacity, H: High cutoff capacity.
- ④ ■V: Rated voltage.

© 2023 Yamaha Guitar Group, Inc. All rights reserved.

Ampeg, the Ampeg logo, Go Anywhere, Venture, Portaflex, SVT, SGT, and Super Grit Technology are trademarks or registered trademarks of Yamaha Guitar Group, Inc. in the U.S. and/or other jurisdictions. Neutrik and speakON are registered trademarks of Neutrik AG Corporation.

The Model and Serial numbers can be found on the product label. Please record these numbers below and retain this document for your records.

Model Number: _____

Serial Number: _____

What's in the Box

Ampeg® Venture® V3, V7, or V12 Amplifier, Power Cable, Quick Start Guide.

Introduction

Go Anywhere™

Ampeg Venture Series amplifiers and cabinets deliver the modern style and features sought by contemporary bassists—continuing a tradition of innovation that stretches back to the dawn of the electric bass. The ultra-portable Venture amplifier heads are small and light enough to fit into a gig bag, a laptop bag, or the optional Venture carrying bag, making them ideal for the travelling bassist. The Venture amplifiers pack plenty of punch via the Class D power section—more than enough power to drive any of the Venture Series speaker cabinets or practically any other cab bassists may encounter on their travels.

Through the easy-to-use and intuitive controls, the Venture amplifiers offer an extensive array of tone-shaping tools that include a legacy preamp, 3-band EQ with sweepable Mids, Ultra Hi and 3-way Ultra Lo switches, and a Super Grit Technology™ (SGT™) Overdrive circuit with SVT® and B15 voicings. An effects loop, an XLR direct output, an Aux input, and a Phones output enhance connectivity, as does the Neutrik® speakON® high performance speaker outs. The Venture V7 and V12 models additionally include a Preamp Out and Poweramp In for even greater flexibility. All circuitry is analog except for the solid-state Class D amplifier. Add an optional AFS2 footswitch for remote control of the SGT overdrive and other functions, and an optional heavy-duty padded Venture carrying bag to protect your Venture Series amplifier.

In order to get the most out of your new amplifier, please fully read this *Owner's Manual*, as well as the *Important Safety Instructions* included with your Venture Series amplifier, before you begin playing.

Features

- Legacy Preamp with 3-band EQ
- New sweepable Mids
- Ultra Hi/3-way Ultra Lo switches
- SGT Overdrive Circuit with SVT and B15 voicing switch
- Lightweight and compact
- 300 Watts (V3), 700 Watts (V7), and 1200 Watts (V12) @ 4 ohms
- Effects loop, XLR DI out, Aux input, Phones output
- Preamp Out and Poweramp In (V7 and V12 only)
- Neutrik speakON speaker outputs (V3 offers a speakON - ¼" combo output)
- AFS2 footswitch for SGT overdrive and other functions (sold separately)
- Heavy-duty padded Venture carrying bag (sold separately)

Getting Started

1. Read and understand the included *Important Safety Instructions*.
2. Make sure the Power switch is off before making any connections.
3. Insert the included line cord securely into the amplifier's IEC connector. Plug the line cord into a grounded AC outlet. The amplifier will accept the appropriate voltage as indicated on the rear panel.
4. Connect an instrument to the Input jack with a 1/4" (shielded) instrument cable.
5. With all controls fully off, turn the amplifier on by flipping the Power switch to "On."
6. While playing the instrument, adjust the Volume knob to the preferred level.
7. Adjust the EQ knobs and switches to taste.

Hookup Example - Venture V3

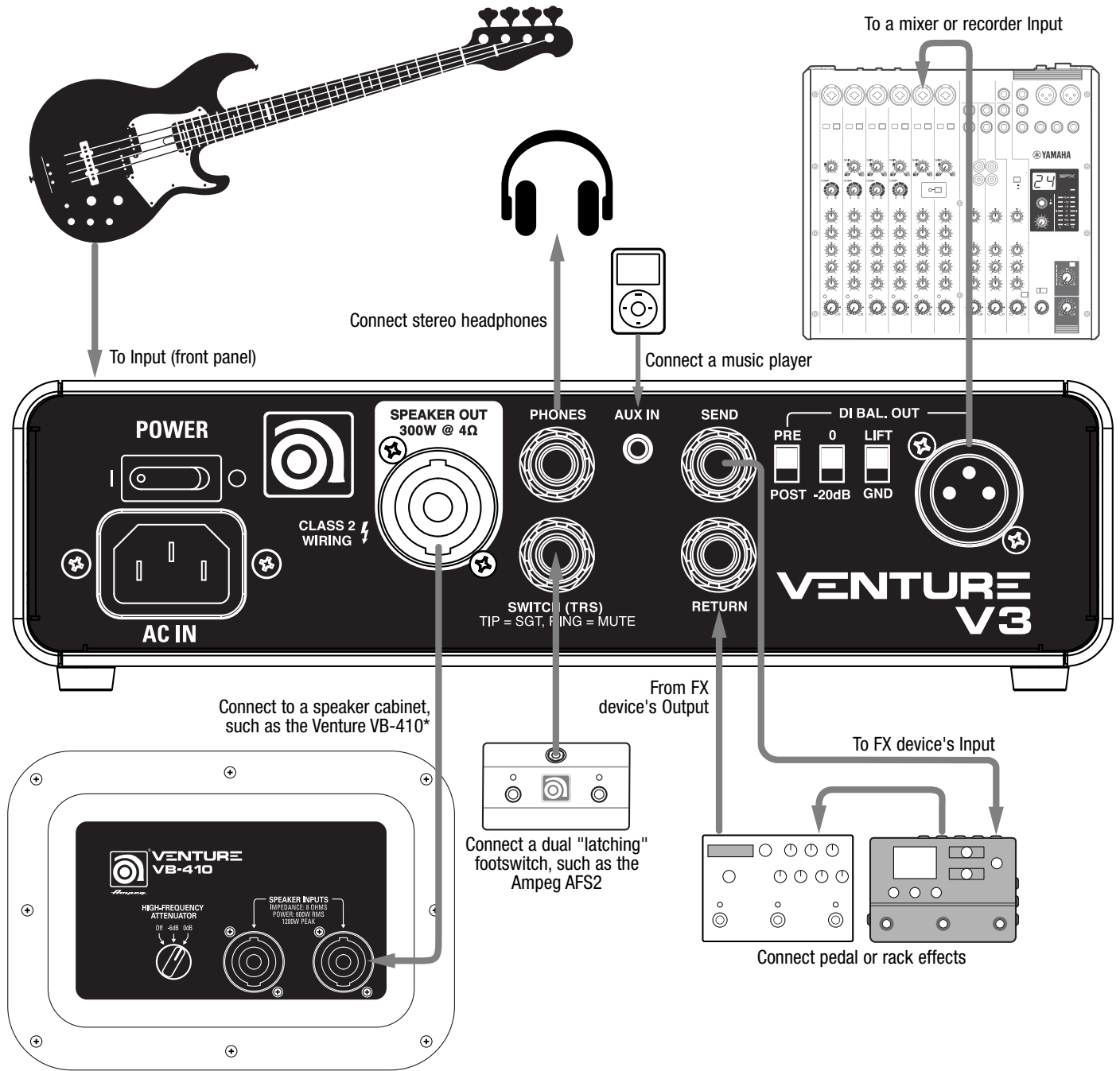

***NOTE:** Total impedance for all connected speaker cabinets should never be less than 4 Ohms. Always use speaker cabinets with the same nominal impedance when using more than one cabinet.

Hookup Example - Venture V7 and V12

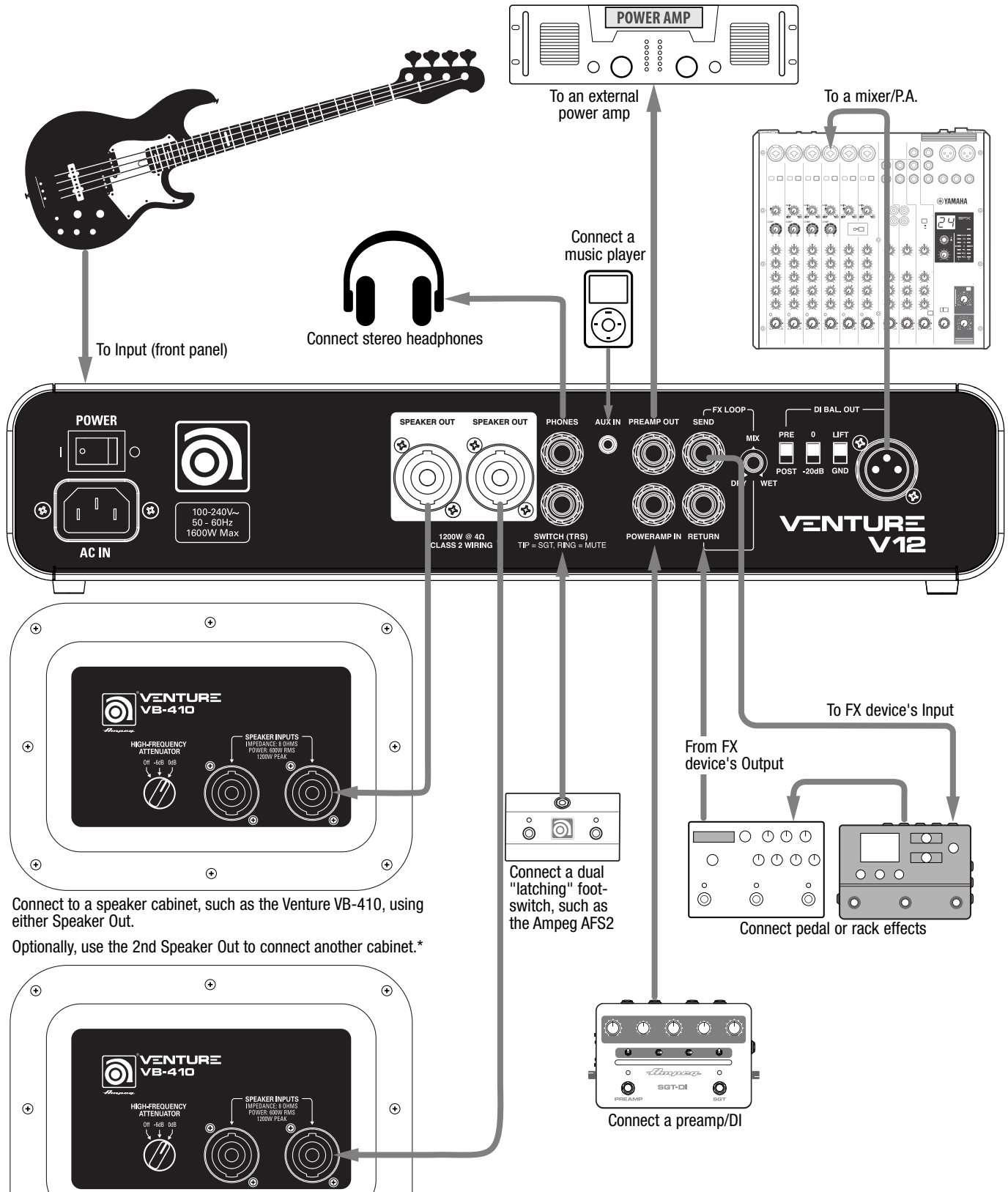

***NOTE:** Total impedance for all connected speaker cabinets should never be less than 4 Ohms. Always use speaker cabinets with the same nominal impedance when using more than one cabinet.

Front Panels

V3

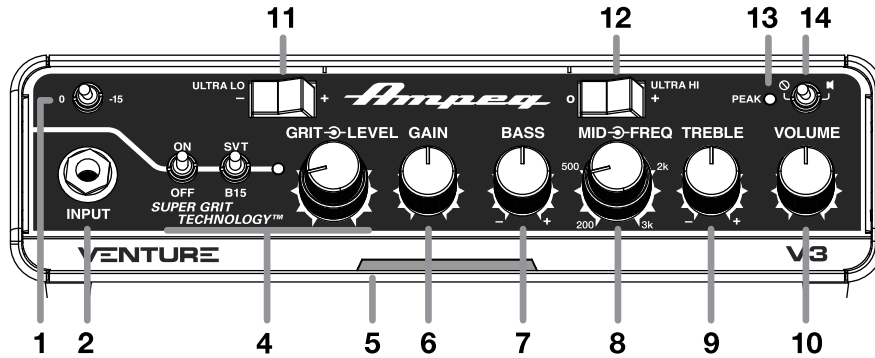

V7



V12



Front Panel Descriptions

1. **0 dB / -15 dB Input Switch:** Use this switch to configure the optimal input level. Typically, you'll want to use the -15 dB setting with instruments that include high output pickups or active electronics, or if you frequently see the Peak LED [13] light up.
2. **1/4" Input:** Connect a passive or active instrument to the Input jack. Use the 0dB / -15dB switch [1] to set your preferred input level.
3. **Compressor:** (V7 and V12) Adjust the knob clockwise to lower the threshold and add compression to your signal, up to a 10:1 voltage ratio maximum. Set the knob fully counter-clockwise to turn the compressor off. The LED at the left lights to indicate whenever your input level exceeds the compressor's threshold and gain reduction is applied.
4. **SGT (Super Grit Technology) Circuit:** Use the SGT to add classic Ampeg overdrive.
 - On/Off Switch:** Enables or disables the SGT circuit. (Alternatively, the SGT can be toggled via the rear panel's Switch jack—when a footswitch is connected, this front panel switch is disabled.)
 - SVT/B15 Switch:** Toggles between two “flavors” of overdrive, based on the character of either the legendary SVT or Portaflex® B15 tube amplifiers.
 - SGT Grit/Level Knob:** This dual-concentric knob offers independent adjustment over the amount of grit (the inner control) and output level of the circuit (the outer control).
5. **Power/Mute Indicator LED:** This LED bar lights up blue when the amplifier is powered on, and lights up red when the Mute switch [14] is engaged.
6. **Gain:** Use to adjust the signal level driving the preamplifier.
7. **Bass:** Use to adjust the low-frequency level of the amplifier for up to 14 dB of boost or cut at 40 Hz. The low-frequency output is flat at the center position.
8. **Midrange Frequency/Level:** Use the dual-concentric knob's outer control (Freq) to select the midrange frequency and the inner control (Level) for up to 14 dB of boost or cut.
9. **Treble:** Use to adjust the high-frequency level of the amplifier for up to 17 dB of boost, or -14 dB of cut at 4 kHz. The high-frequency output is flat at the center position.
10. **Volume:** Use to control the amplifier's overall output level. It affects the Speaker, Phones, and Preamp outputs.
11. **Ultra Lo 3-way Switch:** Push the left side of the switch to cut the low-frequency output -20 dB at 40 Hz. Push to the center position to disengage Ultra Lo. Push the right side to enhance the amount of low-end with a 2 dB boost at 40 Hz and -10 dB cut at 500 Hz.
12. **Ultra Hi 2-way Switch:** Push the right side of the switch to engage and enhance the amount of high-frequency output by 9 dB at 8 kHz.
13. **Peak LED:** This LED lights up whenever your input signal is too high. (You can use the -15 dB switch [1] to reduce your input level, if needed.)
14. **Mute Switch:** Flip this switch left to mute the amplifier's outputs—see the table below for mute behaviors. The Power/Mute Indicator LED [5] illuminates red when this switch is engaged. (Mute can optionally be toggled via the rear panel's Switch jack.)

Mute Behaviors

When Mute Switch is Engaged:	V3	V7	V12
Outputs Muted	Speaker Out FX Loop Send DI Out	Speaker Outs FX Loop Send DI Out Preamp Out	
Output Not Muted	The Aux Input signal at the Headphones Out (All other input signals are muted at the Headphones Out)		

Rear Panels

V3

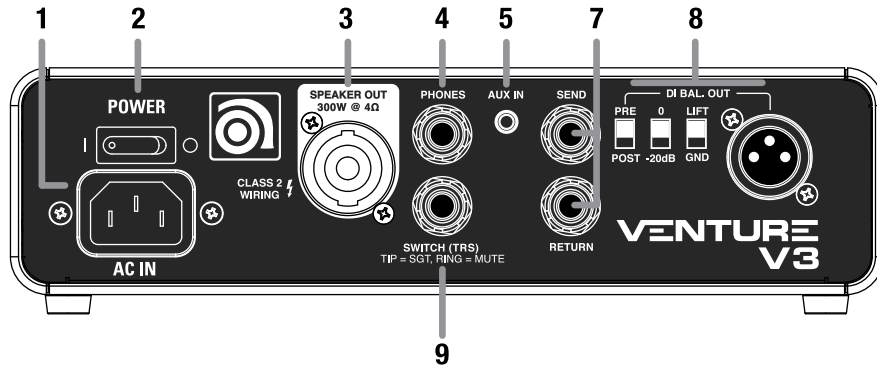

V7

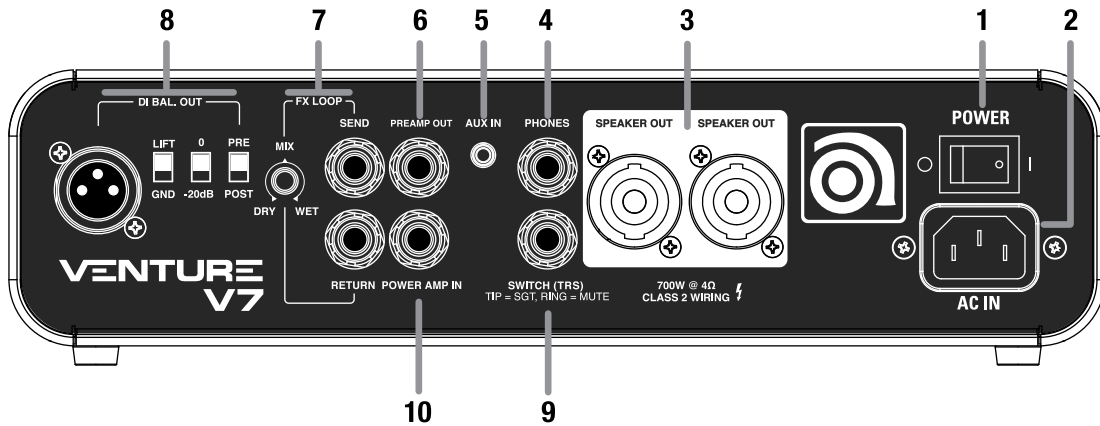

V12

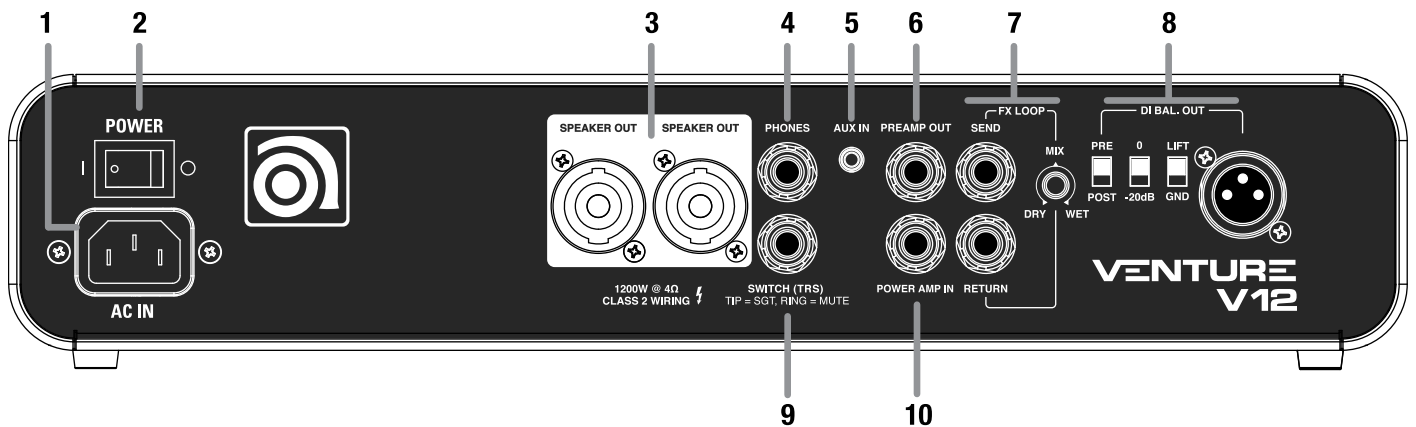

Rear Panel Descriptions

1. **Power Switch:** Use this switch to toggle amplifier's power on (I) and off (O).
2. **IEC Power Cable Connector:** Plug in your included IEC power cable here and connect it to a properly grounded outlet for AC power.
3. **Speaker Output:**

 **IMPORTANT!** To avoid damage to your Venture amplifier, the total speaker impedance load must be 4 Ohms or greater.

Venture series amplifiers include several protective features to safeguard against overtemperature, overcurrent, and high-frequency bursts, to ensure safe, reliable, and prolonged operation of your amplifier for years to come. On rare occasions, when driving a 4 Ohm load via the Speaker Outs at extreme volume levels, the Venture series amplifiers can enter a protective mode to prevent exceeding the safe maximum power rating. If the unit goes into its protective mode, it will recover automatically within 10 seconds. If experiencing shut-downs, be sure to decrease the amplifier's gain and/or volume to safer levels.

Speaker Out (V3): Connect from the Neutrik speakON - 1/4" combination jack into an external speaker cabinet. It is preferred to use the NL2 speakON cable connection between your amplifier and cabinet, due to the secure locking connection and superior high-current, low-noise performance. You can optionally use a standard unshielded, 1/4" TS cable connection. Make sure the total speaker impedance load is 4 Ohms or greater.*

Speaker Outs (V7 and V12): Connect from the Neutrik speakON jack(s) into external speaker cabinets using NL2 speakON type cables. The two outputs are wired in parallel, and you can use either one or both.* Make sure the total speaker impedance load is 4 Ohms or greater. For example, you could connect: Two 16 Ohm speakers (an 8 Ohm load), Two 8 Ohm speakers (a 4 Ohm load), or one 4 Ohm speaker.

 ***NOTES:** Always use speaker cabinets with equivalent nominal impedance when connecting multiple cabinets. Please also see the Ampeg Venture Speaker Cabinets' documentation, available at ampeg.com/support/manuals/.

4. **Phones:** Connect your headphones to this 1/4" TRS stereo output to monitor a mix of the line-level signals reaching the amplifier and any audio from the front panel 1/4" input jack.

 **IMPORTANT!** Always turn the amplifier's Volume knob down to minimum before connecting headphones to avoid potential hearing damage.

 **TIP:** If you just want to listen and practice through headphones "silently," disconnect the Speaker Outputs [3]. There is no harm caused to your Venture series amplifier by using it without speakers connected.

5. **Aux In:** Connect the audio output from line-level sources, such as a mobile device, MP3, or CD player, to this analog, 1/8" TRS stereo input so you can play along to a practice track as you listen with headphones. The Aux In signal is heard only on the Phones output. Adjust the output of your source device for optimal Aux In level.
6. **Preamp Out:** (V7 and V12) Use this 1/4" unbalanced jack to route the preamp circuit's output signal into an external power amp. Connect to this jack using a shielded TS instrument cable.
7. **FX Loop:** The FX Loop Send and Return are line level.

Send: Use a 1/4" unbalanced TS cable to connect to the input of an external FX processor. The Send output is affected by all controls except the Volume. Use the FX Loop Return jack [7] to feed the returned processed signals into the power amplifier.

Return: Use a 1/4" unbalanced TS cable to connect to the output of an external FX processor. Alternatively, you can connect the output of a preamp or other signal source into only the Return jack to route into the Venture power amp circuit.*

 ***NOTE:** When using the Return as an input with nothing connected to the Send, the front panel Input jack, Gain, Comp, SGT, and EQ knobs and switches are disengaged. The Return input signal is also muted when the front panel's Mute switch is engaged.

Mix: (V7 and V12) Turn this knob to adjust the mix between the direct (Dry) and the effects (Wet) signals when the FX Loop is used. Adjust counter-clockwise for a purely direct signal (no effect) and fully clockwise for a purely effected signal (no direct). The fully clockwise position is equivalent to a serial effects loop.



NOTE: Venture V3 amplifiers include a fixed, serial configuration FX Loop, therefore, no FX Mix control is necessary.

8. **DI Balanced Output & Switches:** Use this XLR balanced jack to route your amp's output direct into the input of an external mixer or a recorder—or to an external power amplifier or powered loudspeaker. This DI output is not affected by the amp's Volume knob. Use the front panel's Pad [12], Pre/Post [13], and Ground/Lift [14] switches to configure the DI Output.

Pre/Post Switch: Toggle this switch to configure the DI Balanced Output to be tapped from either Pre or Post specific amplifier controls and components, as follows:

- **In the Pre position (up)** - the DI Out signal excludes, and is not affected by, the -15 dB input pad, compressor, tone controls, SGT settings, and the FX Loop.
- **In Post position (down)** - the DI Out signal includes, and is affected by, the -15 dB input pad, compressor, tone controls, SGT settings, and the FX Loop.

0 / -20 dB Pad Switch: Toggle this switch down reduce the output of the DI Balanced Output by 20 dB.

Ground/Lift Switch: Toggle this switch up to engage the Ground Lift, if necessary, to help eliminate hum at the DI Balanced Output.

9. **Switch (TRS):** Connect a 1/4" TRS dual footswitch to remotely toggle the SGT circuit (tip) and Mute (ring) on/off. If you connect a TS single footswitch, it will toggle the SGT on/off. (Works with Ampeg footswitches AFP-1, AFP-2, and AFS2—or most “latching” type footswitches.)



***NOTE:** The front panel SGT On/Off switch is disabled when a footswitch is connected to the Switch jack. (The front panel Mute switch remains functional when a footswitch is connected.)

When using a 2-button footswitch, a TRS cable is required. When using a 1-button footswitch, a TS cable is recommended for proper functionality. If using a 1-button footswitch with a TRS cable, a problem can occur where, upon insert of the TRS cable, the Mute circuit is engaged and cannot be overridden.

10. **Poweramp In:** (V7 and V12) Use this 1/4" unbalanced jack to route the output of an external preamp directly into the Venture power amp. Connect to this jack from the output of your external preamp using a shielded TS instrument cable. The internal preamp signal is disconnected when a plug is inserted into this jack.

Venture V3 Technical Specifications

FEATURE	VENTURE V3 - VALUES
Output Power Rating @ 1% THD (@ 4 Ohm)	100-240 VAC = 310W
Signal-to-Noise Ratio	80 dB (20 Hz-20 kHz unweighted)
Maximum Gain @ 1 kHz	60 dB
Input Impedance	1 Meg
Power Amp	Class D - ICE power (switching)
Tone Controls	Bass: +/-14 dB @ 40 Hz Mid: +/-14 dB @ selected frequency Treble: +17/-14 dB @ 4 kHz
Power Requirements	100-240 VAC 50-60Hz 450W Max
Size (H x W x D)	2.56 x 9.09 x 10.52 in 65.1 x 231 x 267.1 mm
Weight (approximate)	3.9 lbs 1.77 kg

All specifications subject to change.

Block Diagram

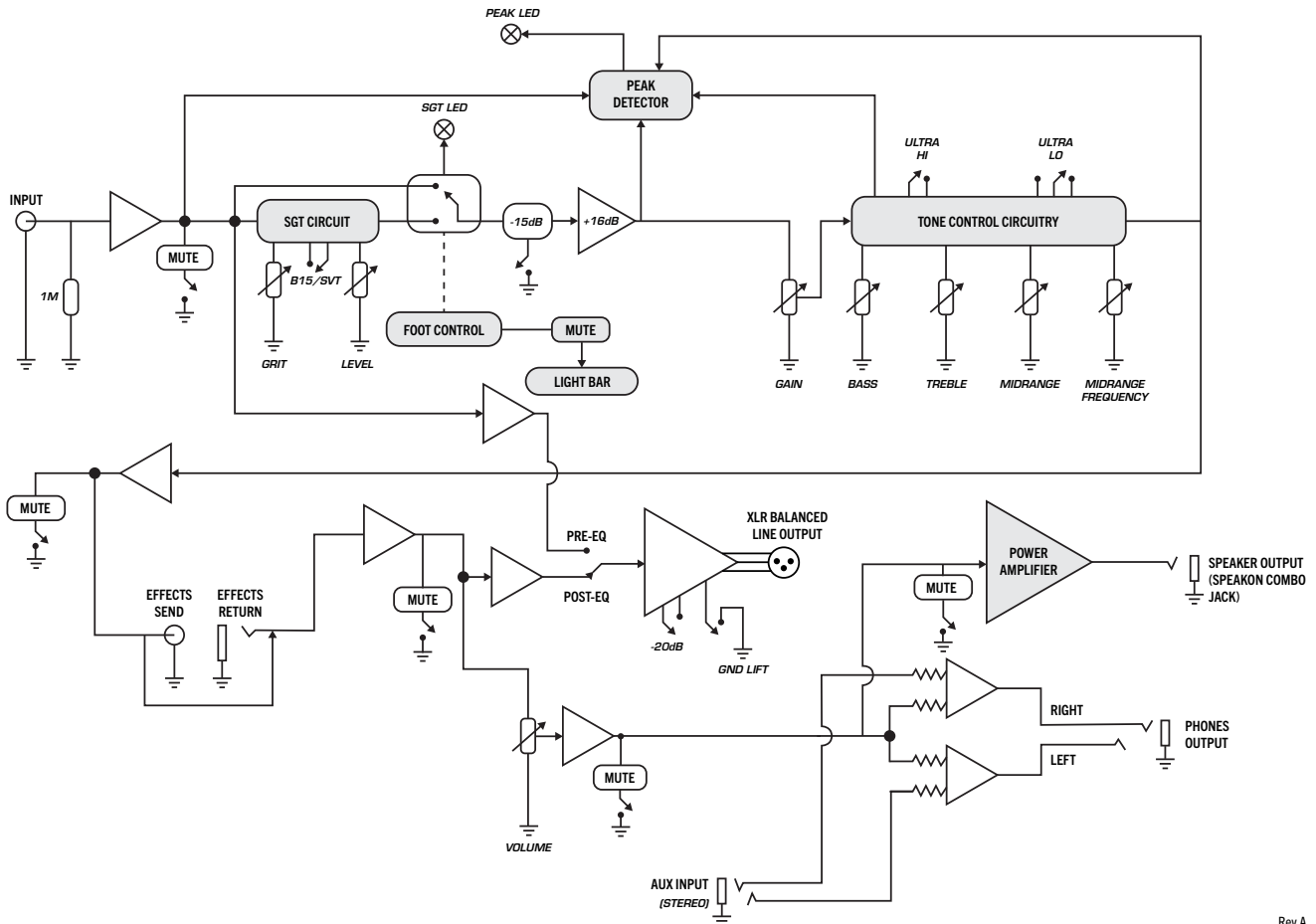

Rev A

Venture V7 Technical Specifications

FEATURE	VENTURE V7 - VALUES
Output Power Rating @ 1% THD (@ 4 Ohm)	100-240 VAC = 700W
Signal-to-Noise Ratio	80 dB (20 Hz-20 kHz unweighted)
Maximum Gain @ 1 kHz	60 dB
Input Impedance	1 Meg
Power Amp	Class D - ICE power (switching)
Tone Controls	Bass: +/-14 dB @ 40 Hz Mid: +/-14 dB @ selected frequency Treble: +17/-14 dB @ 4 kHz
Power Requirements	100-240 VAC 50-60Hz 1000W Max
Size (H x W x D)	3.07 x 11.42 x 10.78 in 78.1 x 290 x 273.8 mm
Weight (Approximate)	6.12 lbs 3.10 kg

All specifications subject to change.

Block Diagram

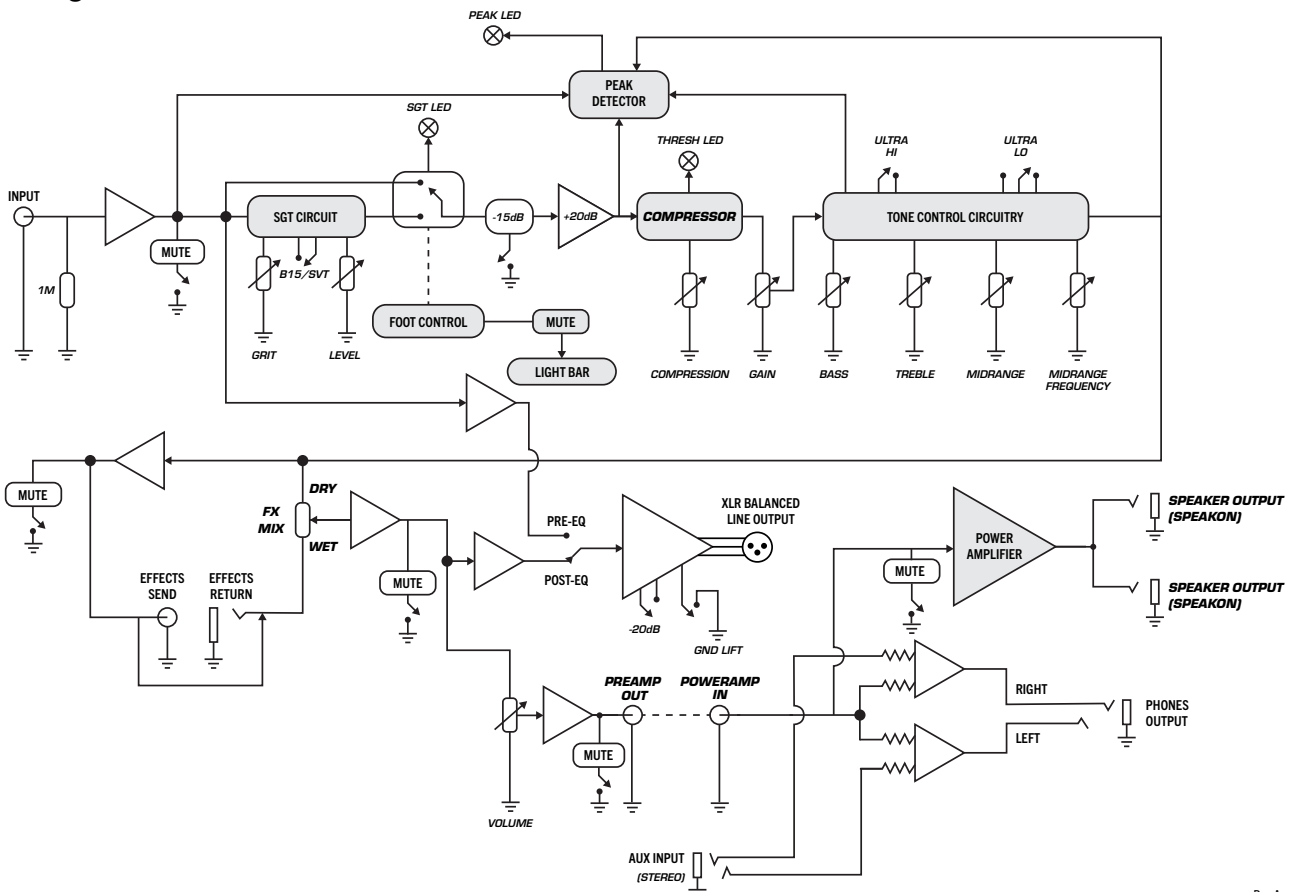

Rev A

Venture V12 Technical Specifications

FEATURE	VENTURE V12 - VALUES
Output Power Rating @ 1% THD (@ 4 Ohm)	100 VAC = 1032W 100-240 VAC = 1220W (The output delta is less than 1 dB between the two outputs at 100V and 240V, respectively.)
Signal-to-Noise Ratio	80 dB (20 Hz–20 kHz unweighted)
Maximum Gain @ 1 kHz	65 dB
Input Impedance	1 Meg
Power Amp	Class D - ICE power (switching)
Tone Controls	Bass: +/- 14 dB @ 40 Hz Mid: +/- 14 dB @ selected frequency Treble: +17/-14 dB @ 4 kHz
Power Requirements	100 VAC 100-240 VAC 50-60Hz 1600W Max
Size (H x W x D)	3.07 x 14.57 x 10.78 in 78.1 x 370 x 273.8 mm
Weight (Approximate)	8.3 lbs 3.76 kg

All specifications subject to change.

Block Diagram

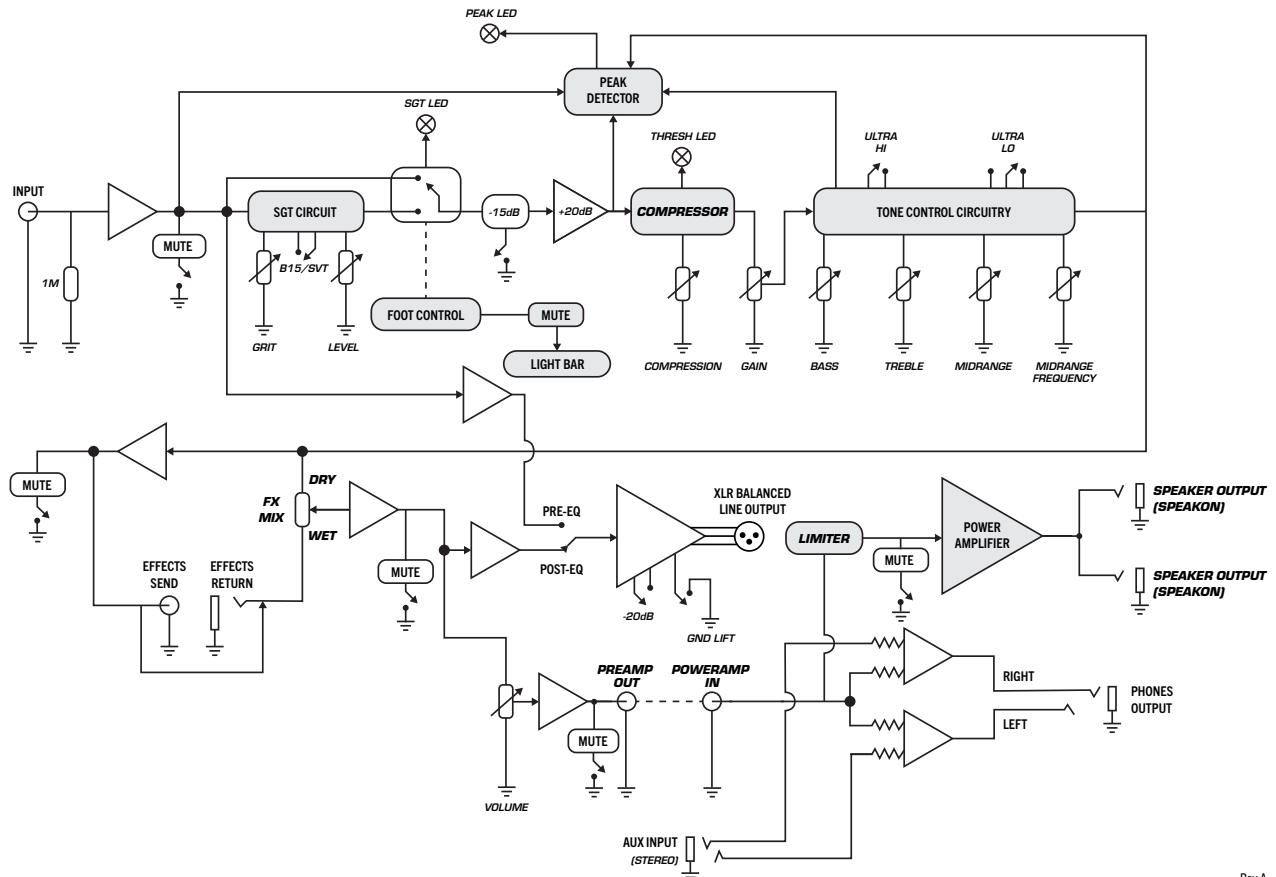

Rev A



Warranty and Support

Visit WWW.AMPEG.COM to...

- (1) ...identify **WARRANTY** coverage provided in your local market. Please keep your sales receipt in a safe place.
- (2) ...retrieve a full-version, printable **OWNER'S MANUAL** (English only) for your product.
- (3) ...**REGISTER** your product.
- (4) ...**CONTACT** Technical Support or call 818-575-3600.

www.ameg.com
Yamaha Guitar Group, Inc.
26580 Agoura Road, Calabasas, CA 91302-1921 USA
Rev. A

